

# STEREO IMPACT

## Suprathermal Ion Telescope (SIT)

### Workmanship Vibration Re-test Plan

*Version a*

13 July 2005

Prepared by:

Steve Wasserzug  
Steve Wasserzug, STEREO/ISE

14 JUL 05  
Date

Reviewed by:

[Signature]  
STEREO QA Representative

15 Jul 05  
Date

Approved by:

[Signature]  
Tycho von Roseninge, SIT Project Manager

FOR TYCHO VON ROSENINGE  
7/15/2005  
Date

## Table of Contents

1	Introduction.....	3
1.1	Scope.....	3
1.2	Purpose.....	3
1.3	Applicable Documents.....	3
2	Test Approach and Requirements.....	3
2.1	Sine Survey.....	3
2.2	Random Vibration .....	3
3	Test Responsibilities .....	4
3.1	Code 660 .....	4
	Code 549.....	4
3.3	Code 400/300.....	4
3.4	Handling.....	4
4	Pass/ Fail Criteria.....	4
5	Test Configuration and Equipment.....	4
6	Instrumentation and Controls .....	5
6.1	Accelerometers .....	5
6.2	Test Tolerances.....	5
7	Test Sequence .....	5
7.1	Pre-test Checklist.....	5
7.2	Test Steps .....	6
8	Data Processing.....	6
9	Photographic Documentation .....	7
	Figures.....	7

# 1 Introduction

## 1.1 Scope

This plan describes the workmanship random vibration test of the STEREO IMPACT Suprathermal Ion Telescope (SIT) FM-2. The plan includes test configurations, levels, tolerances, facilities, instrumentation locations, data recording, and data analysis. This plan does not include SIT preparation, handling, or functional testing, which are called out in SIT procedures.

## 1.2 Purpose

The purpose of the tests is to screen for workmanship after replacing the FM-2 detector and internal foil. The test will consist of a one-axis, workmanship-level, random vibration test.

## 1.3 Applicable Documents

1. 7381-9003, APL, *STEREO Environment Definition, Observatory, Component and Instrument Test Requirements Document*
2. 7381-9012, APL, *STEREO IMPACT Interface Control Document*
3. *STEREO IMPACT Suprathermal Ion Telescope (SIT) Acoustics and Vibration Functional Test*

# 2 Test Approach and Requirements

## 2.1 Sine Survey

SIT will undergo protoflight vibration testing in three axes. A 0.25 g sine survey shall precede and follow each vibration run in each axis. See Table 1.

**Table 1: SIT Sine Survey Spec**

Frequency, Hz	Survey Level
5-2000	0.25 g

Sweep Rate: 4 octave/minute

## 2.2 Random Vibration

Table 2 [1] shows the workmanship-level random vibration spec for SIT, which is taken from GEVS. Test runs at lower levels shall precede each random vibration run. The full-level random vibration test run can proceed directly from the lower-level runs without stopping; a 0.25 g sine survey will precede and follow the full-level run. Narrow-band notching up to 10 dB at resonance frequencies can be added to keep responses within 6 dB of input. Larger notches require approval from the STEREO-APL lead structural engineer.

**Table 2: GEVS Workmanship Random Vibration Spec**

Axis	Frequency, Hz	Workmanship Level
Parallel to Mounting Panel	20	0.01 g <sup>2</sup> /Hz
	20 - 80	+ 3 dB/octave
	80 - 500	0.04 g <sup>2</sup> /Hz
	500 - 2000	- 3 dB/octave
	2000	0.01 g <sup>2</sup> /Hz
	Overall	6.8 g <sub>rms</sub>

Duration: 1 minute per axis, 3 orthogonal axes

Notch 2Z  
Channel 12  
@ -6 dB

20 - 0.04 g<sup>2</sup>/Hz  
80 - 0.16 g<sup>2</sup>/Hz  
500 - 0.16 g<sup>2</sup>/Hz  
2000 - 0.04 g<sup>2</sup>/Hz

 7-15-05  
mk 7-15-05

20 Hz - 0.16 G<sup>2</sup>/Hz  
80 Hz - 0.48 G<sup>2</sup>/Hz  
500 Hz - 0.48 G<sup>2</sup>/Hz  
2000 Hz - 0.16 G<sup>2</sup>/Hz  
(full level)

### 3 Test Responsibilities

#### 3.1 Code 660

Goddard Code 660 will provide SIT for a workmanship test in a flight-like configuration. Code 660 will also provide fasteners to bolt SIT to the vibration plate.

Code 660 will provide a cognizant engineer, who will have overall responsibility for SIT, including set up, GSE, and handling.

Name of cognizant engineer: Steve Wasserzug

#### 3.2 Code 549

Code 549 will provide a test director who will be responsible for safe and timely execution of the dynamic tests to the requirements specified herein. The test director will examine all dynamic test data immediately following each test run and, with concurrence of the cognizant engineer, will give the go ahead for successive test runs and test tear down at the end of each vibration test axis. The test director will produce a test report within three weeks after testing.

Name of test director: Michelle Gibson

Code 549 will also provide test operators to perform tests as described in this test plan. The branch will also provide technicians to install accelerometers and force gauges for vibration testing. Accelerometers will be cleaned and applied just prior to vibration testing; this activity will be coordinated with Code 660 and should be done after final bagging of the instrument.

Code 549 will provide a vibration plate with hole patterns suitable for mounting a SIT instrument; Section 10 contains a drawing taken from the SIT ICD, which shows the hole pattern.

#### 3.3 Code 400/300

A Quality Assurance representative shall monitor all test operations involving flight hardware.

#### 3.4 Handling

SIT shall be handled with the following precautions in place.

- Lumalloy bagged for transport in an ESD tote.
- Portable ground strap used to move test article between cart and shaker.
- Use wrist straps whenever handling.
- ESD-safe gloves.
- Use ESD-safe smocks whenever handling the test article.

### 4 Pass/ Fail Criteria

SIT will have successfully passed the workmanship-level vibration test if structural integrity is maintained throughout the test program, as verified by visual inspection and functional testing performed by the cognizant engineer.

### 5 Test Configuration and Equipment

For the vibration test, SIT FM-2 instrument will be assembled on the shaker as shown in Figure 1 of Section 10. The vibration plate shall be drilled for control and monitor accelerometers. The torque applied to the instrument mounting bolts shall be  $19 \pm 2$  lb. The bolt torque must be rechecked (and adjusted as needed) after 15 to 30 minutes because the Ultem® spacers at the interface creep; after the pre-load has stabilized, the test can proceed.

## 6 Instrumentation and Controls

### 6.1 Accelerometers

Accelerometer control will be used for the test. The SIT test article will be instrumented with two tri-axial accelerometers, as described in Table 3 and shown in Figure 1 of Section 10. The accelerometer blocks will be installed on Kapton tape.

**Table 3: SIT Response Accelerometer Locations**

Accelerometer Designations	Accelerometer Location
1X, 1Y, 1Z	Electronics Enclosure
2X, 2Y, 2Z	Telescope Housing

All control and response data will be recorded for all test runs. The recorder will operate at a speed sufficient to provide a minimum of 2500 Hz upper frequency response for random vibration testing.

### 6.2 Test Tolerances

Random vibration tests shall be conducted within the following tolerances:

spectral values:  $\pm 3$  dB when measured in frequency bandwidths of 25 Hz or less.

wide band (RMS) level:  $\pm 1.5$  dB

frequency:  $\pm 5\%$

time:  $\pm 5\%$

## 7 Test Sequence

### 7.1 Pre-test Checklist

The following is a list of some of the steps required before testing occurs. Write in additional steps as required.

Check off	No.	Steps (add to this list as required in space provided)
✓ LG 7/15/05	1	Clean the SIT instrument and its vibration plate
✓ LG 7/15/05	2	Document and verify the SIT test configuration.
✓ LG 7/15/05	3	Verify facility ground strap is attached to interface plate.
* ✓ LG 7/15/05	4	Install SIT to vibrate plate for z-axis shake. Torque bolts to 17-21 in-lb. 19 in-lb
✓ LG 7/15/05	5	Install SIT accelerometers as specified in Table 3 and the figures.
✓ LG 7/15/05	6	Verify installation of the control accelerometer onto the vibration plate.
	7	GND strap from SIT was stored under bagging - Nutcrack team
	4a	in strap while accessing for connection. Replace with spare strap.
	8	Torque to 6 in lb. operator @ 7-15-05 QA LG 7/15/05 NO STRAP
	9	Torque strap to plate @ 4 in lb. @ 7-15-05 QA LG 7/15/05
	4b	
	10	

- Re-Torque  
@ 19 in lb,  
LG 7/15/05

\* Live mount torque analysis  
1/7/05 cal 1/7/06 ave  
SN G02687  
AN C26030

Document SIT FM-2 Test Configuration

Mounted for z-axis shake. Bagged, with feet exposed.  
 No connectors mated (including no survival heater bus monitoring). No blankets.

(SW)

7-15-05

7.2 Test Steps

The test will be conducted in the sequence shown in the table below. Reference 3 contains a handling procedure. Functional checkouts are performed per Section 6.3 of Reference 3.

SIT FM #2	Z-AXIS	Date:	
#	Steps	Results, comments, and observations	Initials
1	Verify that SIT mounting is oriented for a z-axis shake.		LG 7/15/05
2	Run low-level sine survey, examine response plot, and record fundamental frequency, $f_0$ .	$f_0 = 288 \text{ Hz}$	(SW) 7-15-05
3	Run pre-random check out at -18 dB (and at other levels as required). -12 dB and -6 dB runs too.		(SW) 7-15-05
4	Run full level random vibration.	Notched @ first mode. See redline.	7-15-05 (SW)
5	Run low-level sine survey and compare to pre-test survey.	$f_0 = 288 \text{ Hz}$ ✓	(SW) 7-15-05
6	Perform visual inspection and functional test per Reference 3.		

8 Data Processing

Data reduction will be required for all control data between test runs along with some or all of the response data. All data will be reduced from the full level test runs for inclusion in the test report.

Acceleration plots will be generated between test runs to analyze input, response, and data fidelity. All full level data channels will be plotted in the frequency domain with annotation and in a format suitable for inclusion in the final test report.

Low-level sine survey and sine vibration data will be analyzed and plotted in the following formats:

accelerometers  $g_{pk}$  vs. frequency

Random vibration data will be analyzed and plotted in the following formats:

accelerometers  $g^2/Hz$  vs. frequency (20-2000 Hz)

## 9 Photographic Documentation

Digital photographs will be taken to show the overall setup with test article fully assembled on the vibration fixture and shaker. Close-up photographs will be taken of the accelerometer installation with sufficient detail to allow later accelerometer location identification.

## 10 Figures

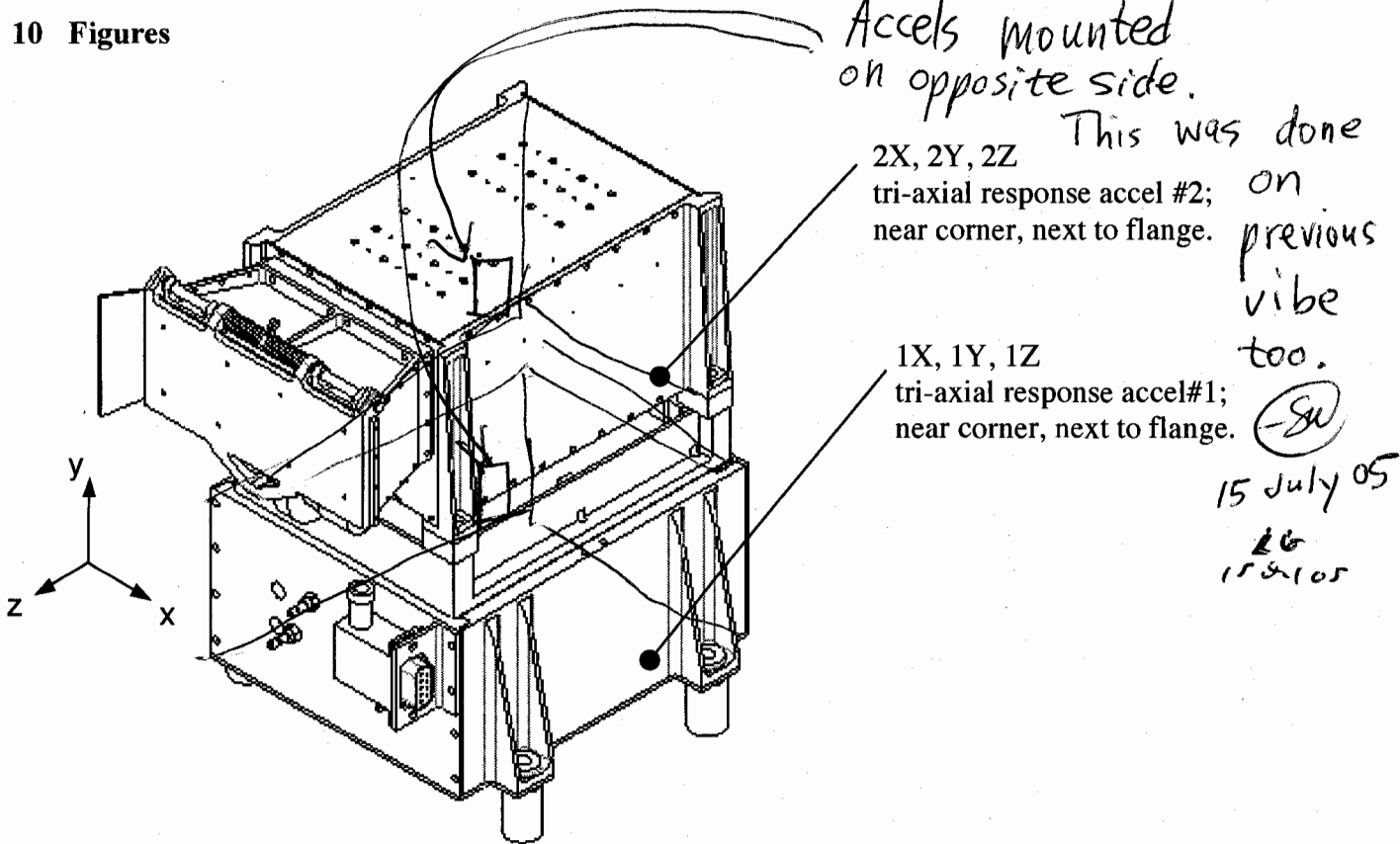
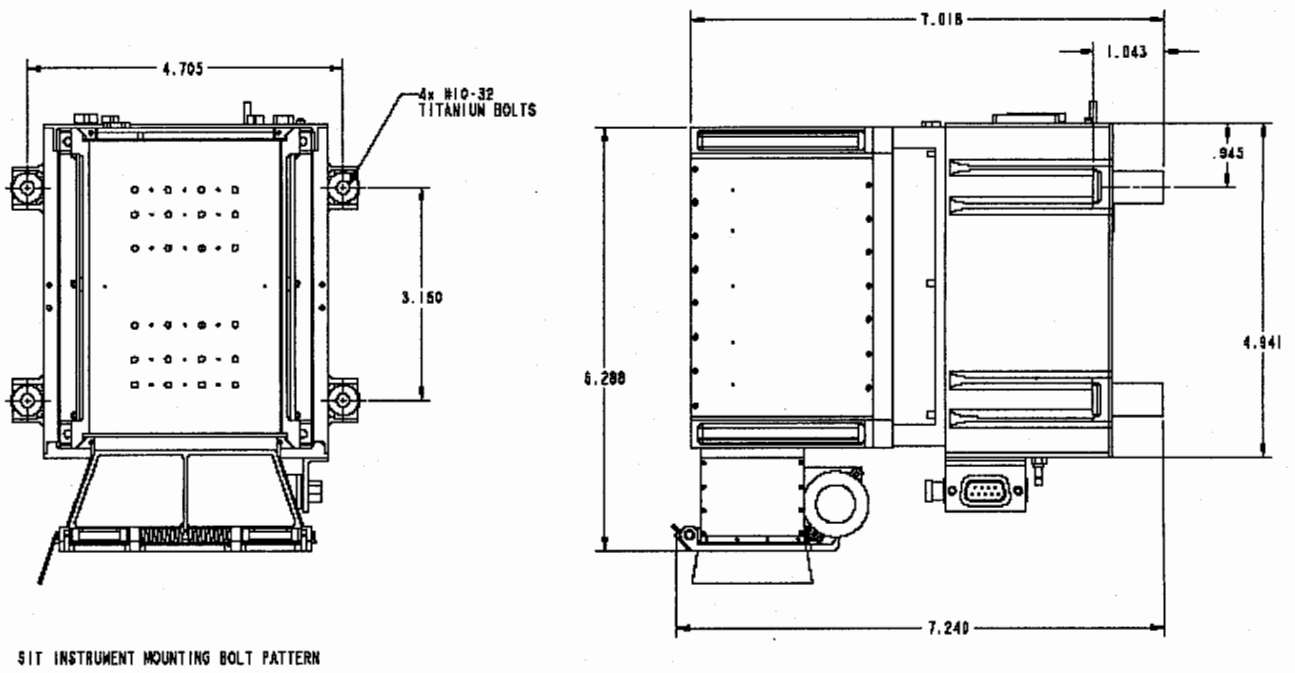

Figure 1: SIT assembly and approximate response accelerometer locations



**Figure 2:** SIT footprint for vibration plate.